

Specifications

Output Power HP (kW)	3 (2.2)
Phase	3 Phase
Pole	2 Pole
Frame Number	90L

Degrees of Protection	IP 55
Enclosure Construction	Totally-enclosed Fan-cooled
Thermal Class	Class F (155 °C)

Alignment	Vertical
Frame Material	Steel plate

Power Transmission	Direct-couple or Belt Driven
Direction of Rotation	Counterclockwise (CCW) viewed from shaft-end side

Connection Type	Terminal Block (6 Leads)
Coating Colour	Munsell N5.5 (Gray)
Conformed Standard	IEC 60034-1 & JEC-2137-2000

Voltage & Frequency	220/380-415V	LT Type 50Hz
	220/440V	60Hz

Motor Characteristics

Type	Hz	V	50% Load			75% Load			100% Load				Torque(%)		Is (A)	Inertia GD ² (kg-m ²)	
			(A)	Eff(%)	PF(%)	(A)	Eff(%)	PF(%)	(A)	Eff(%)	PF(%)	Speed (r/min)	Torque (kg-m)	Ts			Tm
LT	50	220	4.48	0.82	0.79	5.90	0.84	0.87	7.51	0.85	0.90	2850	0.75	345	323	62.0	0.0138
		380	2.60	0.82	0.79	3.42	0.84	0.87	4.35	0.85	0.90	2850	0.75	345	323	35.8	
		415	2.66	0.80	0.72	3.34	0.84	0.82	4.13	0.85	0.87	2870	0.75	415	386	39.1	
	60	220	4.23	0.86	0.79	5.75	0.85	0.89	7.43	0.85	0.91	3430	0.62	276	277	53.3	0.0138
		440	2.38	0.80	0.76	3.06	0.83	0.85	3.82	0.85	0.89	3460	0.62	375	375	35.6	

Dimensions (mm)

Flange Number	Motor							
	D	LA	LB	LC	LE	LG	LL	LZ
FF165	186.3	165	130 j6	200	3.5	12	288.5	12

Terminal Box			Shaft End						
KD	KG	KL	LR	Q	QK	S	T	U	W
PF 3/4	133	156	50	50	40	24 j6	7	4	8

Bearing No.		Approximated Weight (kg)	Approximated Packing Dimensions (LxWxH)	Gross Weight (kg)
Drive End	Opposite			
6205ZZ	6204ZZ	23	425 x 280 x 226	23.8

Connection & Connection Diagram

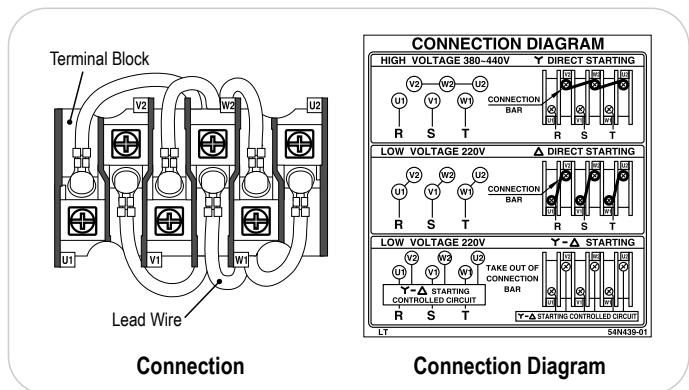

Circumstance Conditions

Ambient Temperature	-20 ~ +40°C
Ambient Humidity	95% RH or less
Operating Altitude	Less than 1,000m above sea level
Environment	No bursting / erosive gas or vapor